

# Supalite Flood Unit

## IP65 commercial and industrial



**Powdercoated steel or polycarbonate IP65 weatherproof enclosure.**

- Standard powdercoated steel enclosure.
- Standard unit complete with flex and plug.
- Standard available in 10w, 12w and 35w halogen lamp combinations.
- Premium range feature high output faceted sealed beam spotlight
- IP65 model robust polycarbonate enclosure.
- IP65 available in 10w, 20w and 35w halogen lamp combinations.
- Single point, Clever-test® DALI compatible or Zoneworks® computerised testing options available.

Clevertronic's Supalite range provides a wide selection of emergency flood units for commercial and industrial use. Supalite flood units can provide indirect emergency lighting where it is not possible to mount conventional emergency lighting, e.g. factory/warehouse applications or outside areas such as loading docks, car parks and evacuation assembly points.

Supalite flood units are available with 10W, 12W or 35W tungsten halogen lampheads. All models use SLA standby batteries charged by constant potential battery chargers for long life.

Supalite floods use an industrial duty powder coated steel control unit that can be wall mounted or positioned on a suitable support. Weather proof versions are available for areas where moisture and/or dust is prevalent. Lamp heads can be easily positioned to cover the egress path.

After installation, compliance testing has never been easier with Clever-test® and Zoneworks® computerised options available across the range. Why waste your valuable time scheduling, performing and then recording emergency lighting discharge tests when the emergency lights can do it themselves?

For more options available please contact Clevertronics.

# Supalite Flood Unit

## Specifications

### CATALOGUE NUMBERS AND DESCRIPTIONS

Please see Clevertronics website for IES files and latest information.

Standard Supalite	TESTING OPTIONS			
	Standard	Clever-test	DALI Em	Zoneworks
2 x 10w Economy	ESF210	N/A	N/A	N/A
2 x 12w Premium	PSF212	DSF212	ZSF212-DALI	ZSF212
2 x 35w Premium	PSF235	DSF235	ZSF235-DALI	ZSF235

*Standard Supalites come with 1.5m flex and plug.*

Description: Twin head surface mounted, non-maintained halogen emergency flood. (Clever-test/ DALI Em/ Zoneworks compatible) Clevertronics Supalite Flood.

IP65 Supalite	TESTING OPTIONS			
	Standard	Clever-test	DALI Em	Zoneworks
2 x 10w Economy	EFW210	N/A	N/A	N/A
2 x 20w Premium	PWF220	DWF220	ZWF220-DALI	ZWF220
2 x 35w Premium	PWF235	DWF235	ZWF235-DALI	ZWF235

Description: IP65 Twin head surface mounted, non-maintained halogen emergency flood. (Clever-test/ DALI Em/ Zoneworks compatible) Clevertronics IP65 Supalite Flood.

Please note, Supalite floods are classified as indirect emergency lighting under the AS2293 Standard and spacing tables and classifications do not apply to this type of luminaire. Specifiers: IES files are available for download from our website or please contact our office for assistance.

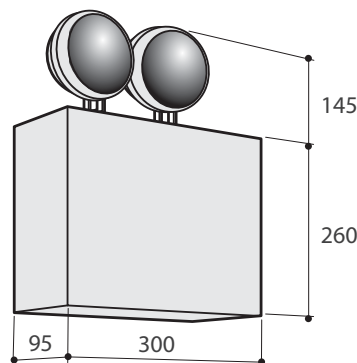

TWIN HEAD SUPALITE

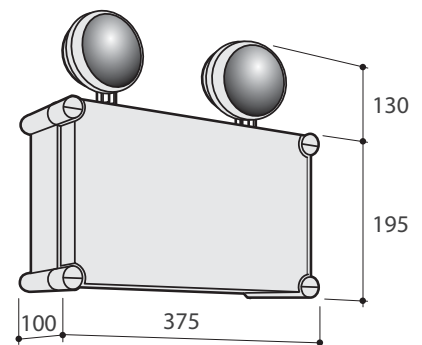

WEATHERPROOF SUPALITE

Please check our website for your closest Clevertronics office and local representative.

[www.clevertronics.com.au](http://www.clevertronics.com.au)

Due to changes in industry standards and Clevertronics policy of product improvement, specification details are subject to change without notice.